

BLUE VALLEY

FLANGING Machines
RING and CIRCLE Shears
ELLIPTICAL HEAD
Shear and Flanger
TUBE FLANGERS
OFFSETTERS

MANUFACTURED AND SOLD BY

BLUE VALLEY MACHINE & MFG. CO.

6830-34 TRUMAN ROAD

KANSAS CITY, MO. 64126

Printed in U.S.A.

Phone 231-1480
Area Code 816

FAX # 816-483-0059

Cable: Blual

Description of Machines

The Blue Valley Flanging Machines have been used by tank fabricators since 1928. Since the first machines went on the market, there has been many changes to improve the machines. These machines are now sold in all parts of the world. If you have never seen them in operation, may we direct you to where you may do so.

Machines are suitable for flanging all kinds of materials. Aluminum, copper, stainless steel, boiler plate, etc. Each of the machine capacities is rated in mild steel.

These Blue Valley Flanging Machines are the fastest flanging machines on the market. For example, a flat head 12' diameter, $\frac{1}{4}$ " thick, by 2 $\frac{1}{2}$ " flange, was flanged in two minutes after the circle was set up in machine and machine was started.

All operations of flanging the heads are performed through a centralized group of controls, located so that the operator has clear view of his work at all times. When the flange is complete the flanging rolls and center holddown are released, giving the operator sufficient room for removing the finished head and inserting the next circle.

Send us your flanging problems, as there are many special jobs that can be handled on these machines by using special attachments.

Standard equipment furnished with machines

Machines are equipped with drives.

Upper air holddown cylinder for complete rigid holding for the heads.

Complete set of flat head flanging rolls.

Motor base.

Complete hydraulic flanging mechanism.

All revolving parts are equipped with roller or ball bearings.

Centers for these machines are now equipped with needle and thrust bearings.

All rolls are made from a high carbon steel, hardened and ground.

Equipment to be furnished by customer for setting up of flanging machine

A foundation for the No. 3, No. 4, No. 6, and No. 8 machines is necessary. We furnish the customer with a plan for them to put the foundation under the machine. This foundation is made from a 12" wide channel. This brings the machines up to a working height of approximately 36". No pit is required for these machines.

An air line with approximately 80 to 100 lbs. pressure is required for the machine, connected to two air valves.

Flat head flanging

Speed of these flanging machines in flanging flat heads is very fast. For example floor to floor flanging time for flat heads 30" to 48" diameter in thickness up to $\frac{1}{4}$ ", will be about 20 to 25 heads per hour.

Description Continued on Next Page

Description of Machines (Continued)

Offsetting attachments

Offset rolls can be furnished on the No. 3, No. 4, and No. 6 machines.

The offset is put in the head at the same time it is flanged with the special set of offset rolls.

For each $\frac{1}{16}$ " material change another set of offset rolls are necessary. The exact offset is machined into the rolls.

By special arrangements at the time the machines are built, we can furnish offset rolls and attachments for offsetting semi-elliptical heads and hemispherical heads. Such as for propane and butane heads.

Coned head attachments

A coned head center is available with the different machines for flanging coned heads. May we check over your work and quote you on these coned head attachments.

Special attachments

During the last 25 years there has been many special type heads flanged or spun on the Blue Valley Flanging Machines. May we check over your work and quote you on anything special in the flanging field.

Special jobs that have been worked out are as follows: Curling, reverse dished heads, oblong heads, trays, baffle plates, etc.

New Hydraulics System for the Flangers:

A separate motor operates the new hydraulic system. The motor and pump is a specially built unit which we must supply here at the factory to your voltages. The operator has only one or two hydraulic valves to operate the flanging roll. The new system will give many more years of trouble free operation.

Dished Head Attachments

Dished head attachments can be added to the No. 4, No. 6, and No. 8 machines. They can be added at time of purchase of machine or at any time later.

The No. 10 Flanger is for standard dished heads and also for semi-elliptical heads (2 to 1 ratio dished heads).

The machines with the dished head attachments do not put the dish in the heads. The dish must be put in the blanks by other means, before flanging on these Flangers.

A $\frac{3}{4}$ " or 1" hole is required in the center of the dished heads.

These dished head attachments are for flanging standard dished heads. By standard dished heads, we mean a 100% dished head or where the radius of dish is equal to the diameter of the head. Rolls can be furnished with a knuckle radius of 6% of diameter of head.

The floor to floor time on $\frac{3}{8}$ " or $\frac{1}{2}$ " mild steel dished heads 6' to 8' in diameter will be approximately 30 minutes per head finished to size. Heavier materials such as $\frac{1}{2}$ " will flange easier than $\frac{5}{16}$ " material in the larger diameters.

The time limit required for change over from flat head flanging to dished head flanging would be less than 30 minutes on the average. The centers must be changed and tipped to the correct angle. There is two rolls to change, and the side rolls must be tipped to meet the head at the correct angle.

No. 3—1/4" Capacity Blue Valley Flanging Machine

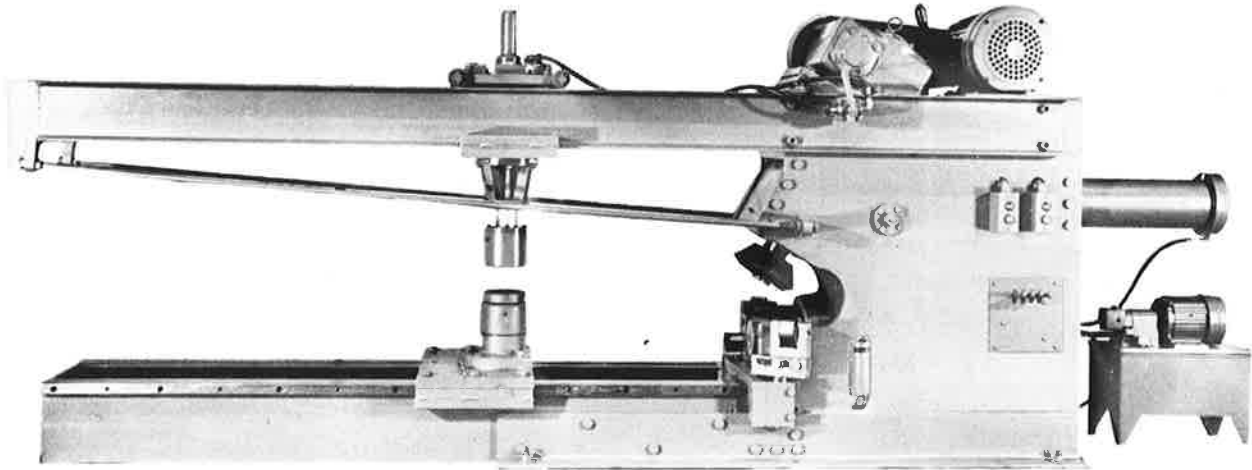

This machine will flange all flat heads from 19" to 12' diameter without any hole in the center of the head. This No. 3 machine is for flat heads only and is not furnished with dished head attachments. Offset rolls are available for this machine. Shipping weight 3,400 lbs. Motor 5 H.P., 1800 R.P.M.

The No. 3 machine is for flanging flat heads only. Dished head attachments are not installed on this machine. The size of the rolls and the height of the machine, does not allow for the dished head attachments.

The range of work is from 19" to 12' in diameter. The maximum capacity in mild steel is 1/4". When working in stainless steel the maximum capacity would be about 60 percent of the 1/4".

Notice the drive on this machine. Gear box drive directly connected to driving roll, with motor mounted on top of machine. This replaces the old fly wheel and the open bevel gears.

Offset rolls can be added to this machine for offsetting the head at the same time that it is flanged.

The upper channels that the holddown cylinder rides on, has been given added bracing by the addition of tie rods.

Tube attachments can be added to this machine.

Further general information is given on pages two and three that will apply to this No. 3 machine.

No. 4—3/8" Capacity Blue Valley Flanging Machine

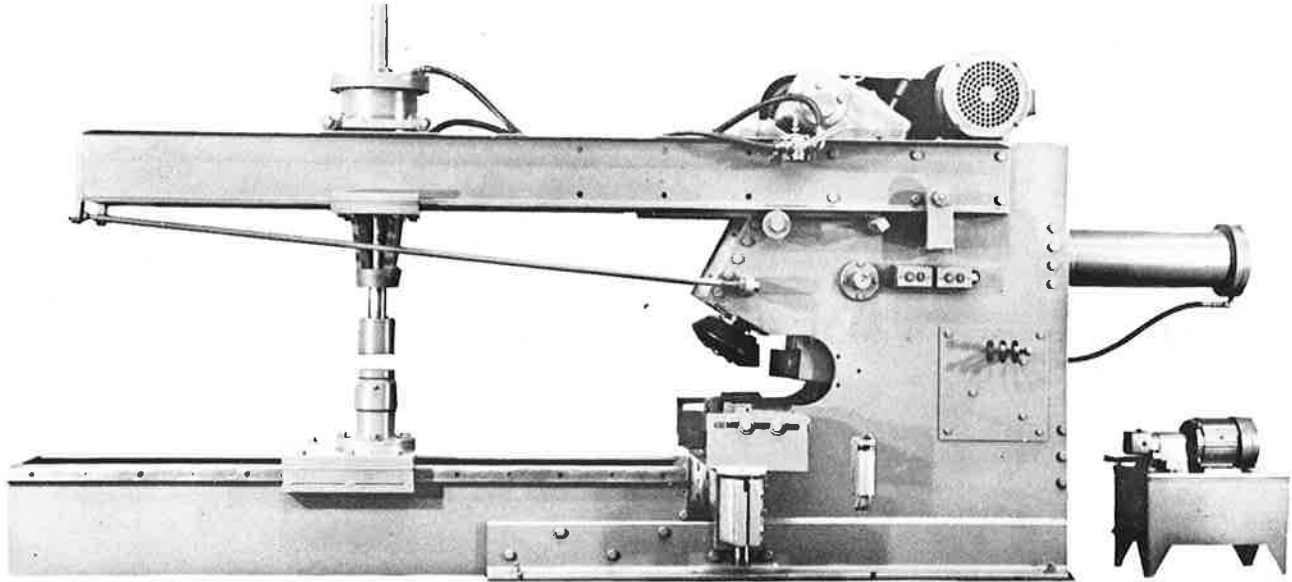

This machine will flange all flat heads from 20" to 12' diameter. Attachments available for flanging dished heads from 30" to 12'. Offset rolls available for this machine. Shipping weight 6,000 lbs. Motor 7½ H.P., 1800 R.P.M.

The No. 4 machine range for flat heads is from 20" to 12'. Capacity is 3/8" in mild steel. About 5/16" in stainless steel.

The No. 4 machine can have dished attachments installed at time of purchase of machine or at any time later. Size range on the standard dished heads on this No. 4 machine is from 30" to 12'. This machine is limited in its flanging of dished heads. The largest knuckle radius that can be put on the machine is 4". Recommended knuckle radii sizes for dished heads is 2", 3" and 4".

Tie rods are furnished with the flat head machines. Where dished head attachments are added, the tie rods are left off.

Tube attachments can be added to this machine.

Further general information is given on pages two and three that will apply to this No. 4 machine.

No. 6—5/8" Capacity Blue Valley Flanging Machine

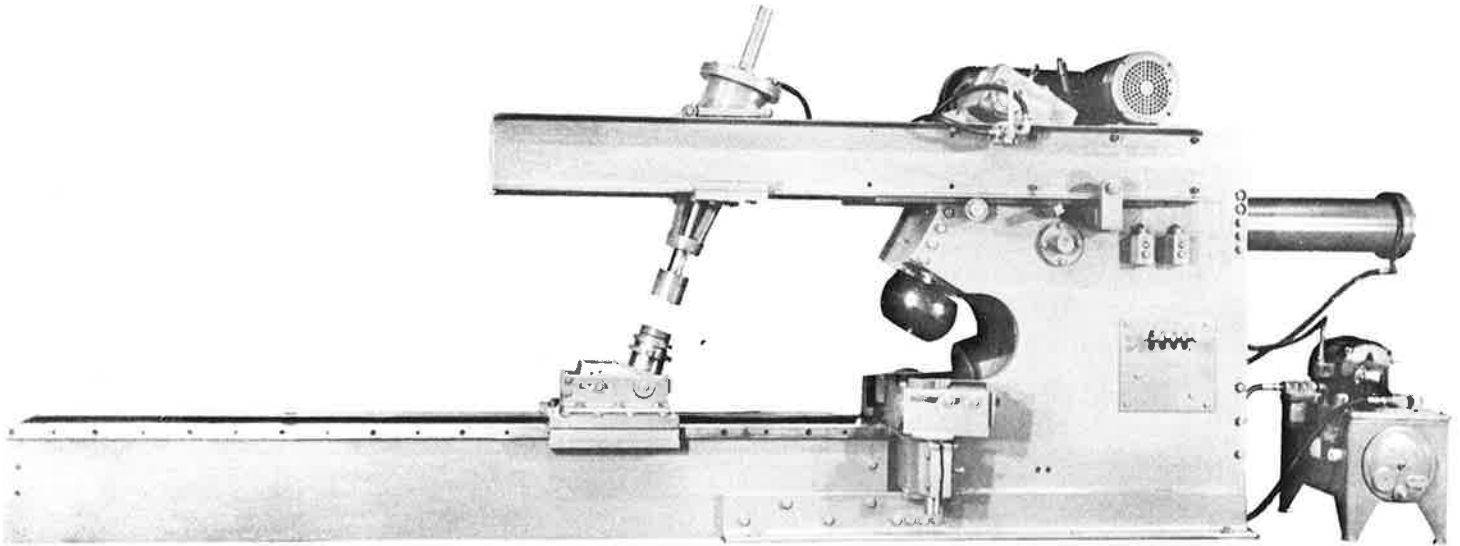

This machine will flange all flat heads from 24" to 20' diameter. Attachments available for flanging dished heads from 36" to 13'. Shipping weight 9,500 lbs. Motor 10 H.P., 1800 R.P.M.

The No. 6 machine has a range in flat heads from 24" to 20'. Capacity is $\frac{5}{8}$ " rated in mild steel. Capacity in stainless steel would be about $\frac{7}{16}$ ".

Dished heads can be flanged on this machine from 36" to 13'. A.S.M.E. Code heads can be flanged up to 96". The largest knuckle radius that can be put on with this machine is $5\frac{3}{4}$ ". Any heads above 96" can be flanged, but the limit on the size of radii is limited to $5\frac{3}{4}$ ".

The radii size that we suggest for the three dished head rolls that we quote as standard equipment is 2", $3\frac{1}{2}$ " and $5\frac{3}{4}$ ". We can make any radii for this machine as long as it does not go over the maximum $5\frac{3}{4}$ ".

If you wish to flange any larger heads with larger knuckle radii than the $5\frac{3}{4}$ ", then it would take the larger flangers.

With this new machine the time limit for flanging dished heads has been cut down considerably. You are able to flange more of the difficult heads than before. Many heads that you were unable to do before can now be flanged on this No. 6 machine as well as the larger machines.

Tube attachments can be added to this machine.

No. 8—1" Capacity Blue Valley Flanging Machine

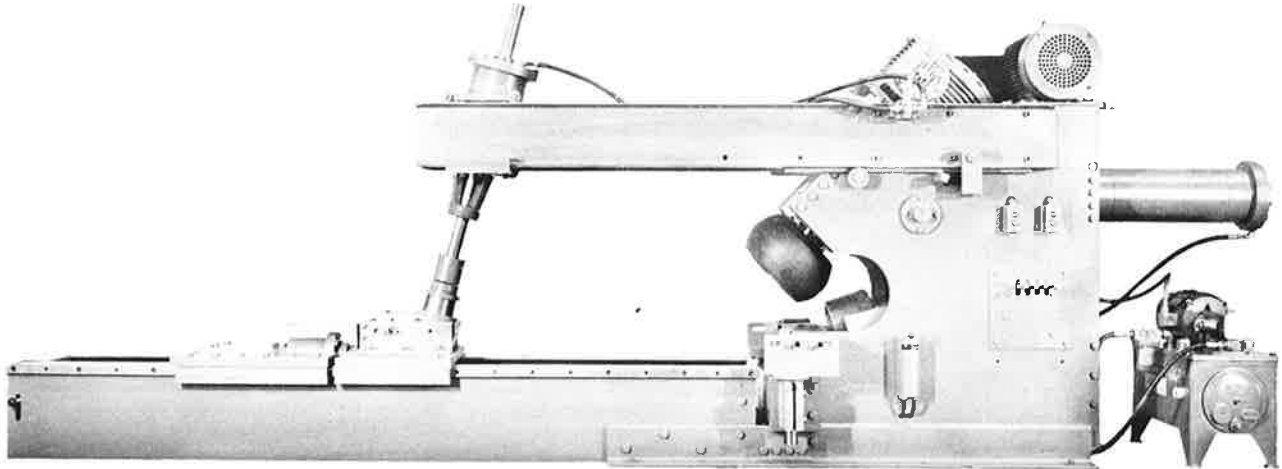

This machine will flange all flat heads from 28" to 20'. Attachments available for flanging dished heads from 36" to 13'. Shipping weight 11,500 lbs. Motor 20 H.P., 1800 RPM

DISHED HEADS UP TO 8" KNUCKLE RADIUS.

The No. 8 machine has a range in flat heads from 28" to 20'. Capacity is 1" rated in mild steel. Capacity in stainless steel work would be $\frac{3}{4}$ ".

Dished heads can be flanged on this machine from 36" to 13'. A.S.M.E. Code heads can be flanged up to about 135". The largest knuckle radius that can be put on this machine is 8". Heads above this 135" can be flanged, but the limit on the size of radii is 8".

The radii size that we suggest for the dished head rolls for this No. 8 machine is as follows: 2", $3\frac{1}{2}$ ", $5\frac{3}{4}$ ", $7\frac{1}{4}$ " and 8". We can give you any radii that you need as long as it does not go over the 8" maximum. Prices of each of the different radii rolls is quoted accordingly to the size of forging used to make the roll.

With this new No. 8 machine, the time limit for flanging dished heads has been cut down considerably. You are able to flange many more of the difficult heads than before.

No. 9—1" Capacity Blue Valley Flanging Machine

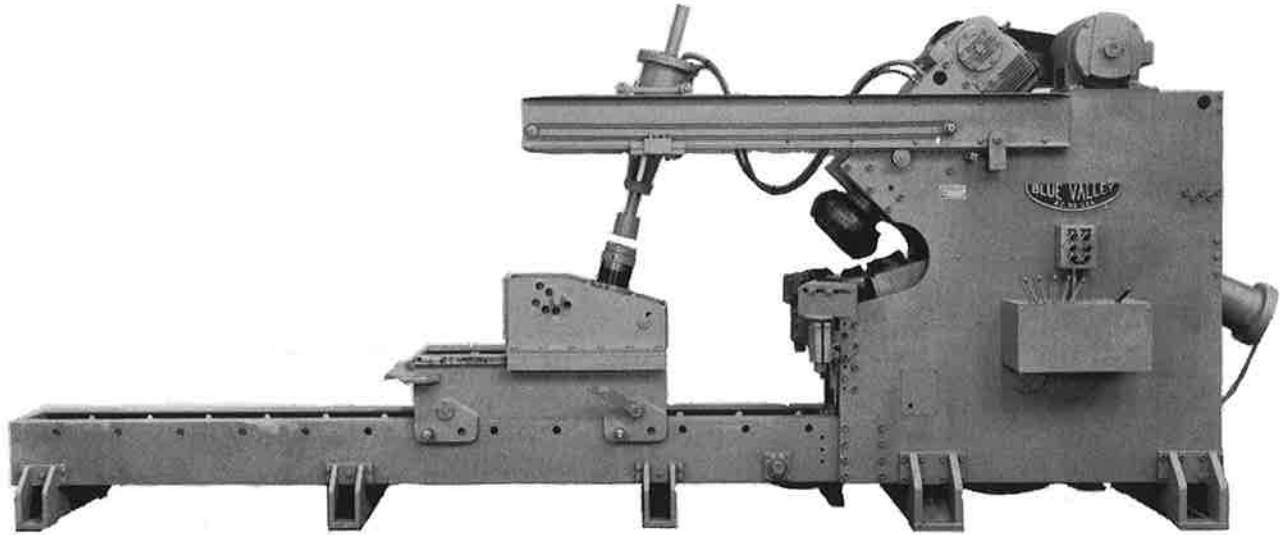

This machine will flange dished heads from 48" to 18'. Shipping weight is 20,000 lbs. Motor is 50 HP, 1800 RPM.

A NEW BLUE VALLEY FLANGING MACHINE FOR FLANGING DISHED HEADS UP TO 12" KNUCKLE RADIUS.

This No. 9 Flanger was developed in 1971. It will give lasting performance under continuous heavy loads.

Dished heads can be flanged on this No. 9 machine from 48" to 18'. A.S.M.E. Code heads can be flanged to 200". The largest knuckle radii that can be put on this machine is 12".

We can supply a special center attachment for this machine for dished heads from 30" to 48". The blank must be bolted down to this small centering device. This center is priced as an extra.

The dished head rolls that fit a No. 7 or No. 8 flanger will fit on this No. 9 flanger.

Size of this machine is: 21 ft. long x 4 ft. wide x 100" tall.

No. 10—1" Capacity Blue Valley Flanging (Spinning) Machine

for dished heads only, with hydraulic tracer

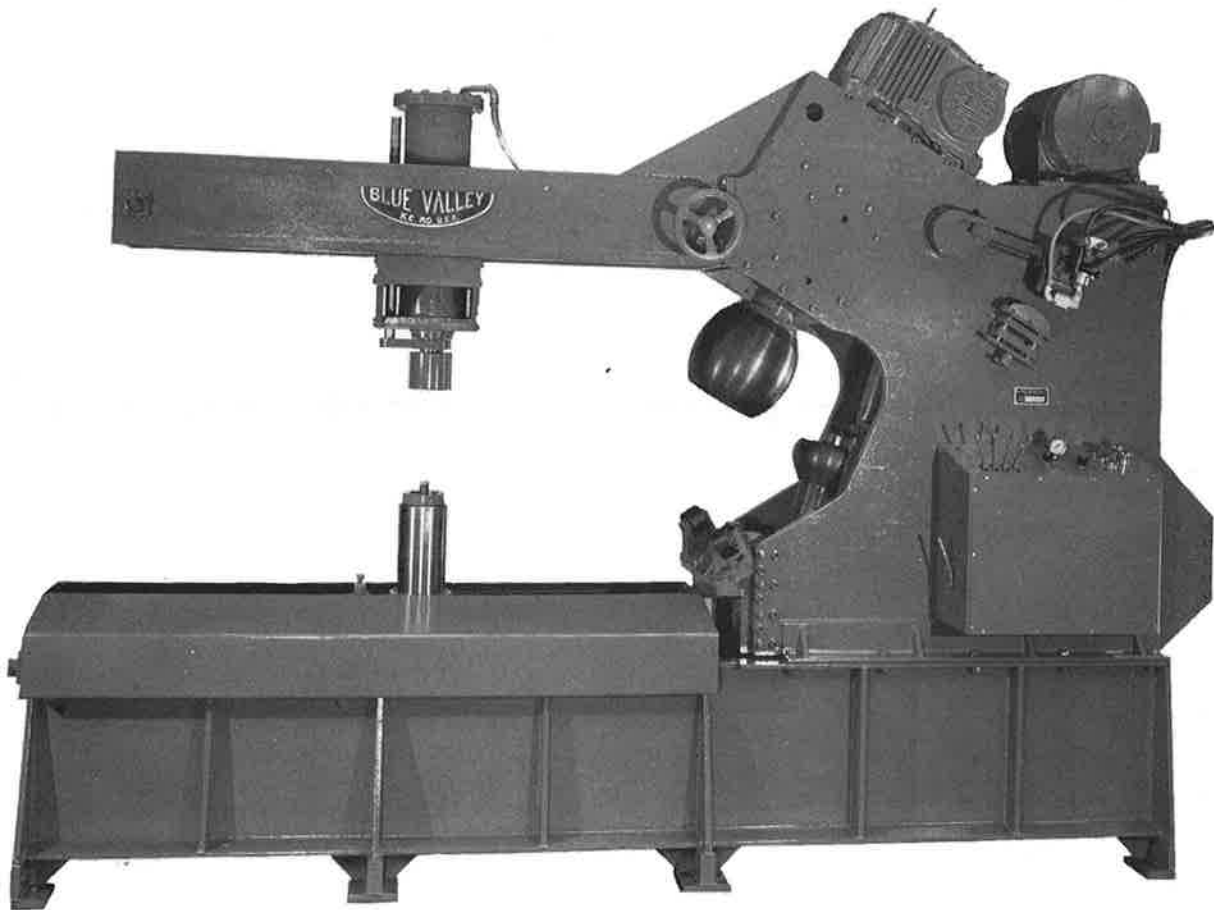

Developed for flanging 2 to 1 ratio dished heads as well as the standard dished heads.

Range of work that can be flanged: 48" to 14' in standard dished heads; 48" to 100" in 2 to 1 ratio dished heads (semi-elliptical). Center attachment available for smaller diameters down to 24". For most any type dished head.

No pit is required. A platform about 14" high will need to be built for the operator to stand on. Center is completely motorized with limit switches for safety at each end. Top holddown cylinder will position with bottom center. The adjustment for the center is by hydraulics. Will adjust up and down as much as 26". Push button controls for all the electrics. Simplified controls for the hydraulics.

By using a tracer with templates the operation of this machine has been simplified. The material is never pressed to the extent of making rough indentations. Gauge thickness is automatically maintained between the large roll and the spinning roll. The Tracer minimizes operator troubles.

Size of machine is: 15' long x about 4' wide x 10' high. Total weight of approximately 25,000 lbs. Machine can be shipped in one piece by low-boy trailer.

Rolls for machine: Largest knuckle radii is 16". Each size roll is priced separately so that you can pick the exact radius needed.

TUBE FLANGING

$\frac{1}{4}$ " (CAPACITY BLUE VALLEY TUBE FLANGING MACHINE) with all tooling and equipment for flanging tubes from 15" to 60" diameter x 60" long in all thicknesses up to $\frac{1}{4}$ "; one upper flanging roll; 5 H.P., 1800 R.P.M. motor, 220/440/3/60; complete with base or foundations.

FLANGE HEIGHTS ON TUBES:

1 $\frac{1}{2}$ " on 10 and 12 Ga. materials

2 " on 3/16" material

2 $\frac{1}{2}$ " on $\frac{1}{4}$ " material

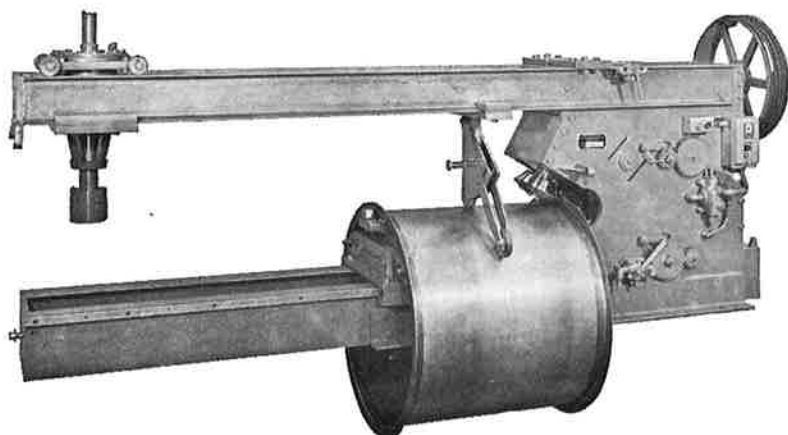
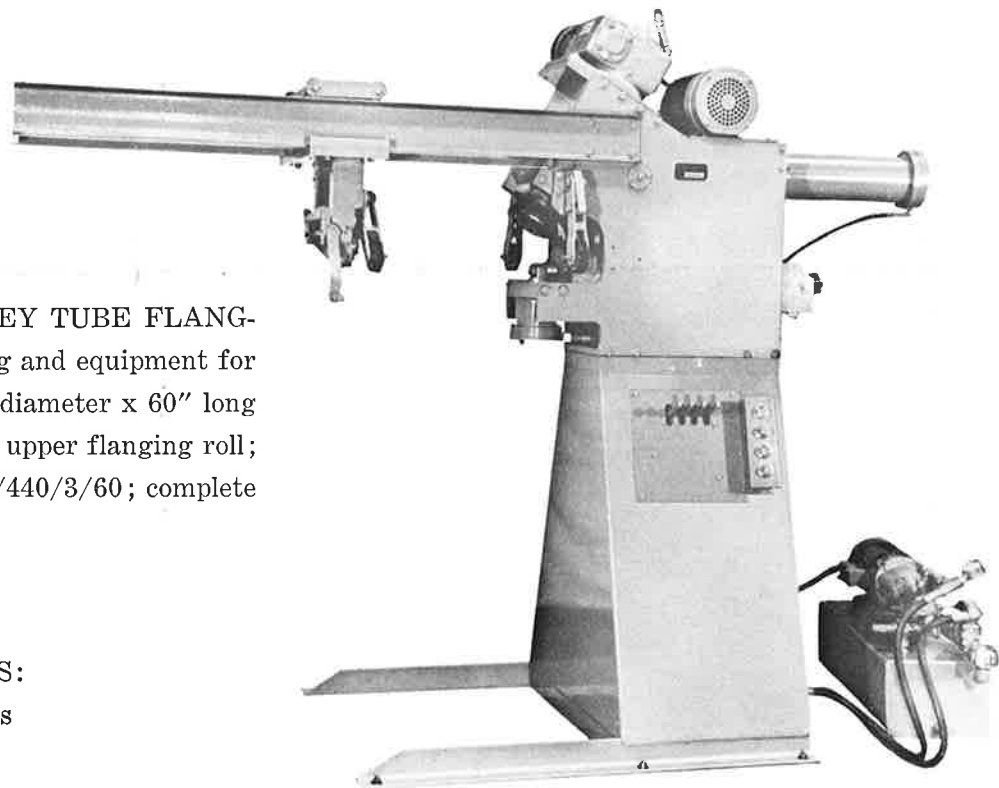

No. 3— $\frac{1}{4}$ " capacity Blue Valley Flanging Machine for flanging flat heads only from 19" to 12'. Equipped with two upper flat head rolls; pneumatic center holddown; 5 H.P. motor, 1800 R.P.M., 220/440/3/60; and with tooling and attachments for flanging tubes from 24" to 60" diameters x 60" long, in all thicknesses up to $\frac{1}{4}$ "; less the foundation, base or pit.

No. 60B—3/8" Capacity Blue Valley Ring and Circle Shear

36" throat

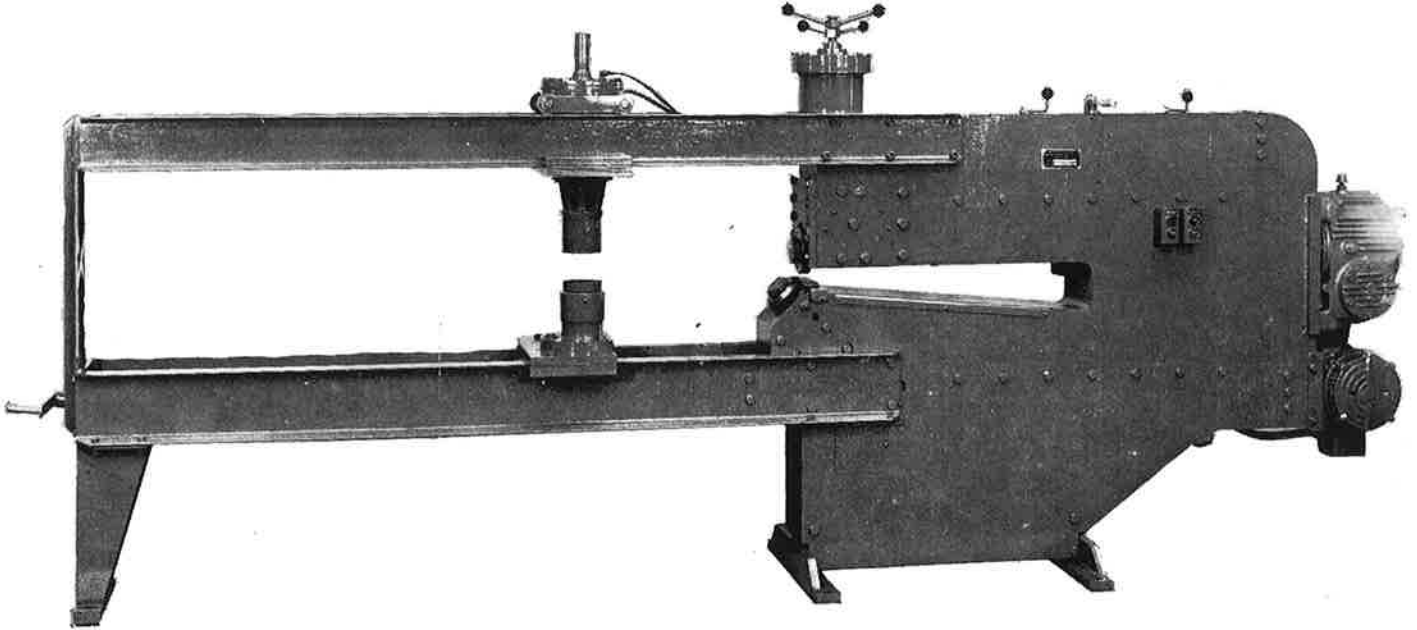

The machine will shear from 15" to 12'3" dia. at speed of 40 feet per minute. Motor is 10 HP, 1800 RPM. Weight 5,500 lbs.

This is same ring and circle shear as the #60 is, excepting the throat depth is 36" on this #60B unit.

MACHINE SIZE: 15' long x 26" wide x 70" high. Weight 5,500 lbs.

CUTTING SPEED: 40 feet per minute.

CENTERING DEVICE: Pneumatic cylinder holddown with hardened serrated shoes mounted in needle and thrust bearings.

AIR PRESSURE required is 60 to 80 lbs.

BASE of machine is built onto machine. No foundation to build.

GOOSE NECK TYPE CENTER available for #60; #60B and #40 shears for shearing from 9" to 15".



This center mounts on carriage plate of shears. Has hand holddown, hardened shoes, center holes.

No. 60—3/8" Capacity Blue Valley Ring and Circle Shear

23" throat

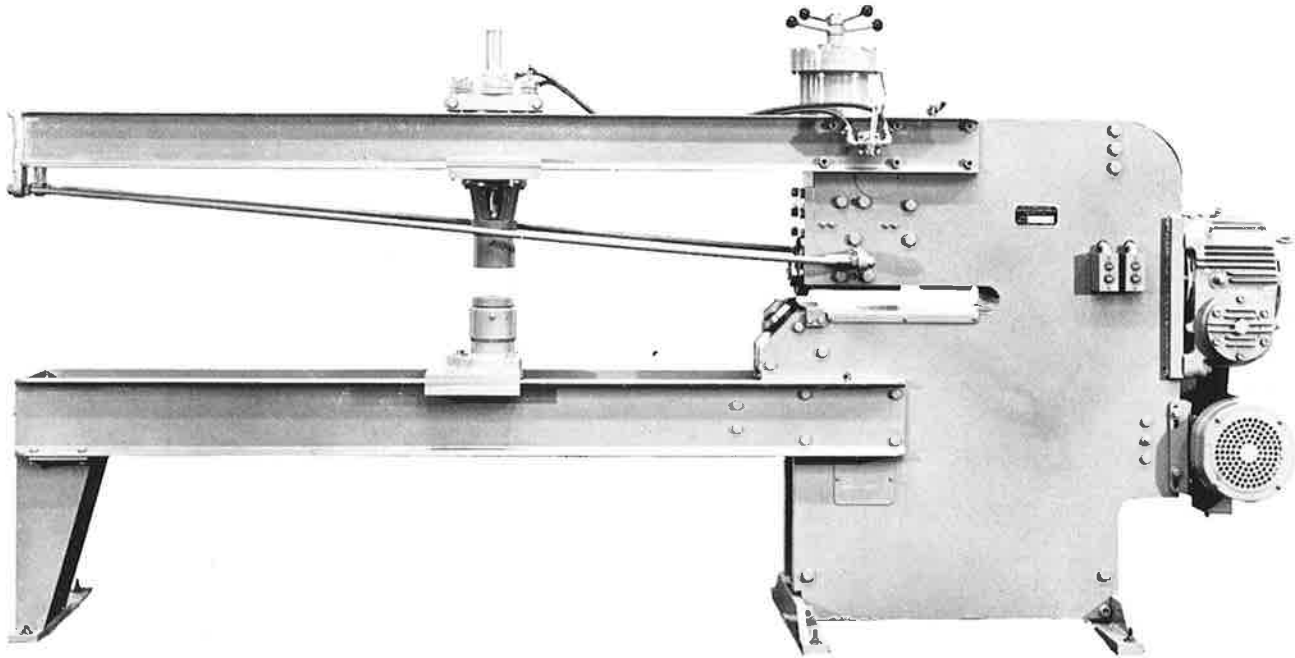

This machine will shear from 15" to 12'3" dia. at speed of 40 feet per minute. Motor is 10 HP, 1800 RPM. Weight 4,000 lbs.

MAXIMUM CAPACITY: 3/8" in mild steel plate up to 12'3".

BOTH BLADES are power driven.

CUTTING SPEED: 40 feet per minute.

HYDRAULIC CYLINDER adjustment for the upper blade. Has lock nut for setting of blade.

LOWER BLADE mounts in machine at 45 degree angle for clearance of scrap. Also lower blade is mounted 1/4" off center.

BASE of machine is built onto machine. No foundation to build.

MACHINE SIZE: 12' long x 26" wide x 70" high. Weight 4,000 lbs.

MOTOR is 10 HP, 1800 RPM; 230/460/3/60.

LENGTH OF THROAT: 23". A 100" circle can be cut from a 100" square blank. Sizes above 100" must have the corners clipped to clear the throat.

CENTERING DEVICE: Pneumatic cylinder holddown with hardened serrated shoes mounted in needle and thrust bearings.

AIR PRESSURE required 60 to 80 lbs.

GOOSE NECK type center available to cut circles down to 9" diameter.

No. 40B—1/4" Capacity Blue Valley Ring and Circle Shear

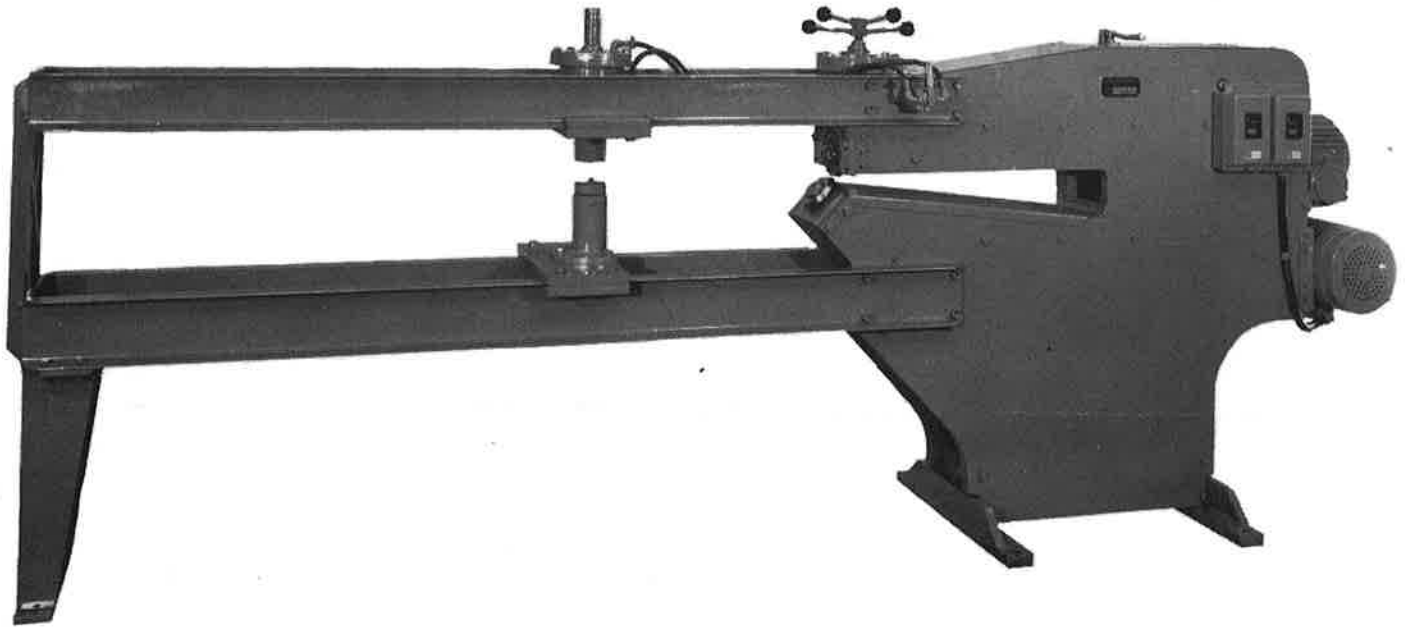

This machine will shear from 12" to 12'3" dia. at speed of 40 feet per minute. Motor is 3 HP, 1800 RPM. Weight 3,000 lbs. 30" throat depth.

MAXIMUM CAPACITY: 1/4" in mild steel plate.

BOTH BLADES are power driven. Top blade is double edged.

HYDRAULIC CYLINDER adjustment for the upper blade. Has lock nuts for setting the blades.

LOWER BLADE mounts in machine at 45 degree angle for clearance of scrap. Also lower blade is mounted 1/4" off center.

BASE comes with machine. No foundation or base to build.

MACHINE SIZE: 10' long x 28" wide x 56" high.

MOTOR is 3 HP, 1800 RPM.

CUTTING SPEED: 40 feet per minute.

This is the same ring and circle Shear as the #40 is, excepting the throat depth is 30" on this #40B unit.

PNEUMATIC CYLINDER on holddown center. Air pressure required 60 to 80 lbs. Centers equipped with Needle and thrust bearings. Goose Neck type center available to cut circle or rings down to 9".

No. 40—1/4" Capacity Blue Valley Ring and Circle Shear

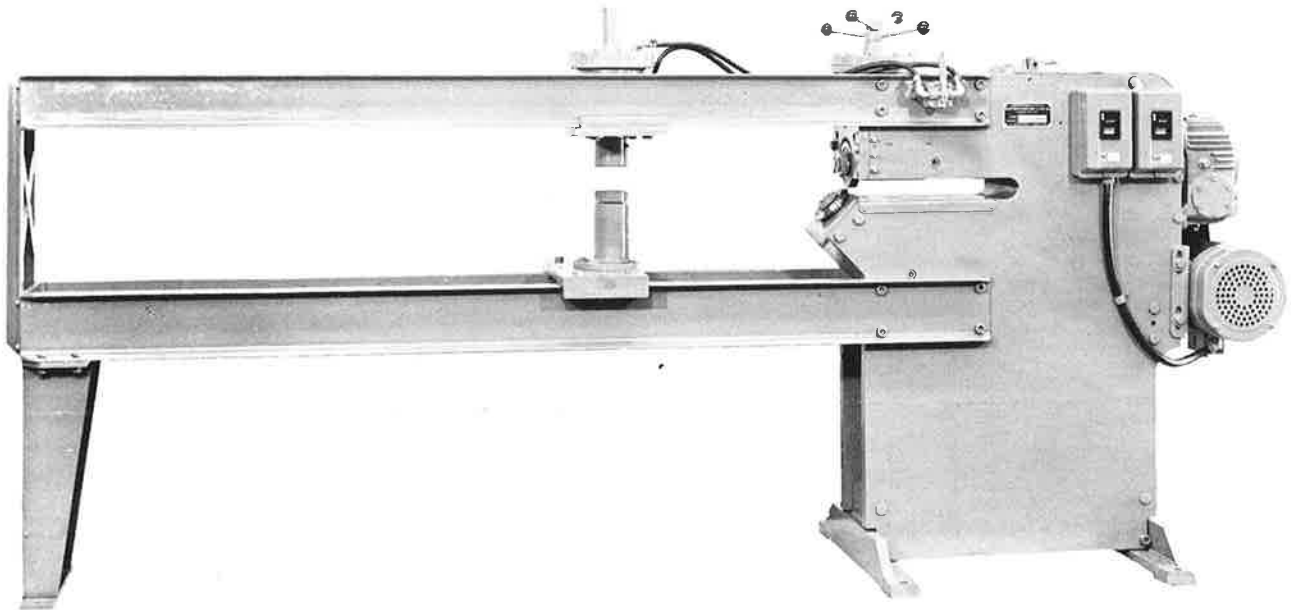

This machine will shear from 12" to 12'3" dia. at speed of 40 feet per minute. Motor is 3 HP, 1800 RPM. Weight 1,800 lbs.

MAXIMUM CAPACITY: 1/4" in mild steel plate.

BOTH BLADES are power driven. Top blade is double edged.

HYDRAULIC CYLINDER adjustment for the upper blade. Has lock nuts for setting the blades.

LOWER BLADE mounts in machine at 45 degree angle for clearance of scrap. Also lower blade is mounted 1/4" off center.

BASE comes with machine. No foundation or base to build.

MACHINE SIZE: 10' long x 28" wide x 56" high.

MOTOR is 3 HP, 1800 RPM.

CUTTING SPEED: 40 feet per minute.

LENGTH OF THROAT is 15 1/2". A 6'0" circle can be cut from a 6' square blank. Sizes above 6' dia. must have the corners clipped to clear the throat.

PNEUMATIC CYLINDER on holddown center. Air pressure required 60 to 80 lbs. Centers equipped with Needle and thrust bearings. Goose Neck type center available to cut circle or rings down to 9".

1/4" Capacity Blue Valley Offsetter for Tubes

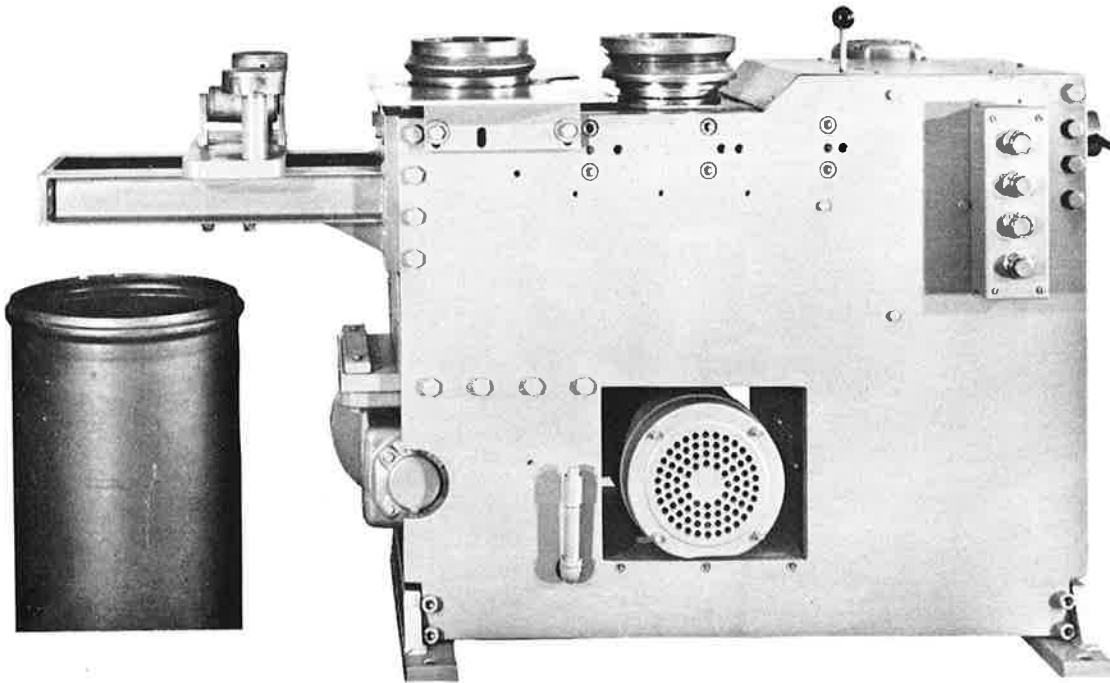

For offsetting tank tubes from 12" to 36". Weight of machine is 2,000 lbs. Motor is 5 HP, 1800 RPM. Machine equipped with hydraulic power unit with 1 HP motor.

1/4" Capacity Blue Valley Offsetter

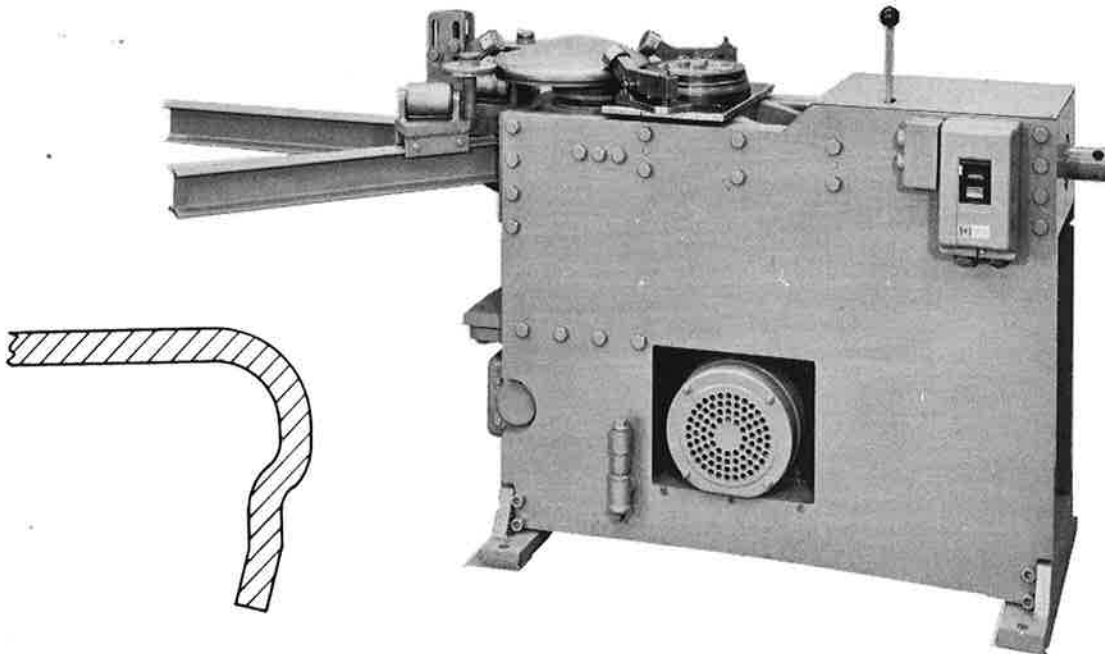

For offsetting tank heads from 12" to 36". Weight of machine is 2,000 lbs. Motor is 5 HP, 1800 RPM. Machine equipped with hydraulic power unit with 1 HP motor.

No. 72—3/16" Capacity Blue Valley Elliptical Head Shear and Flanging Machine

FLANGER

SHEAR

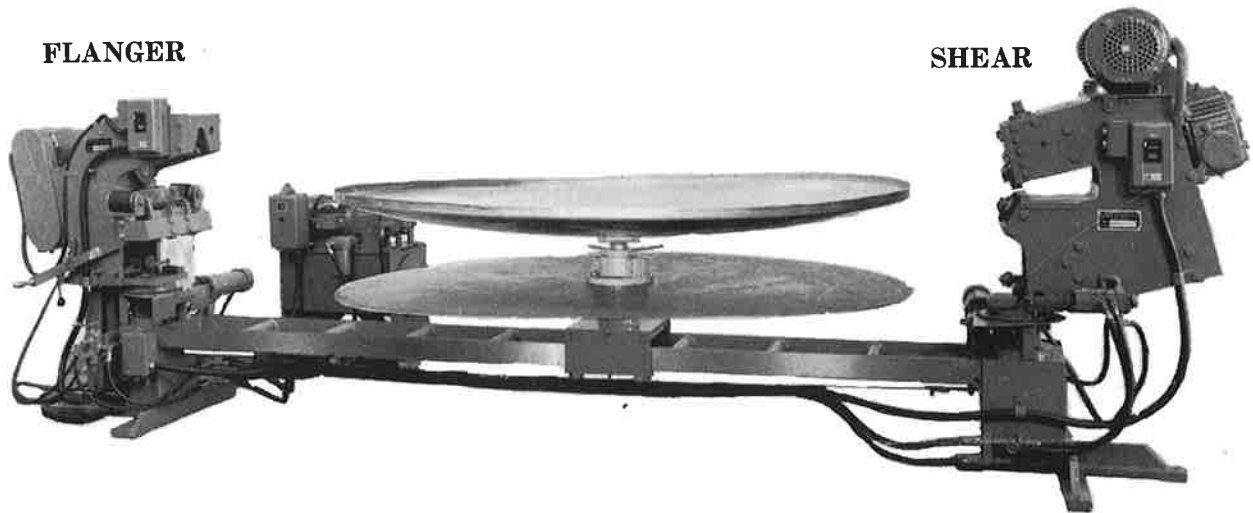

Blue Valley Elliptical Head Shear and Flanging Machine which operates from the same controls. Shears the head to size and shape before flanging it from the same template, without removing it from the machine. Weight of machine, 3,400 lbs.

The Model No. 72 machine is for truck and trailer tank heads primarily. It is adaptable to other shapes. For round heads also. (Do not recommend this machine for round heads because of being much slower than our regular circular machines.)

The first Elliptical Head machine was built in 1939. Several changes have taken place over the years. We now offer a completely changed machine, in the fact that the machines now do the positioning instead of the large hydraulic cylinder and table arrangement for the positioning of the head.

Time limit to shear and flange an elliptical tank head is less than 10 minutes. The No. 72 model machine has been stepped up in speed over the older models. Capable of doing one tank head more per hour. One man is all that is necessary to operate the machine. No hole is required in the heads. It is necessary to tack weld a 1" x 2" x 6" long channel on the blank for holding in machine.

A template of 1/8" material the same size and shape of the finished head is required.

Machine is entirely self-contained, operated by three electric motors.

A flat surface about 15' x 10' is needed for setting up of the machine.

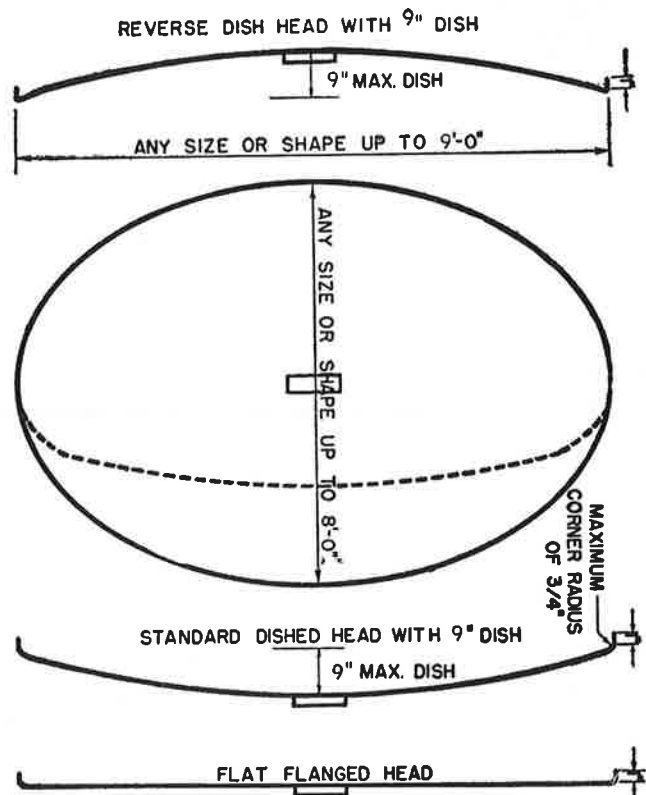

Above is shown a cut of the different type and shape heads than can be sheared and flanged.