

TUBE FLANGER

1/4" Capacity

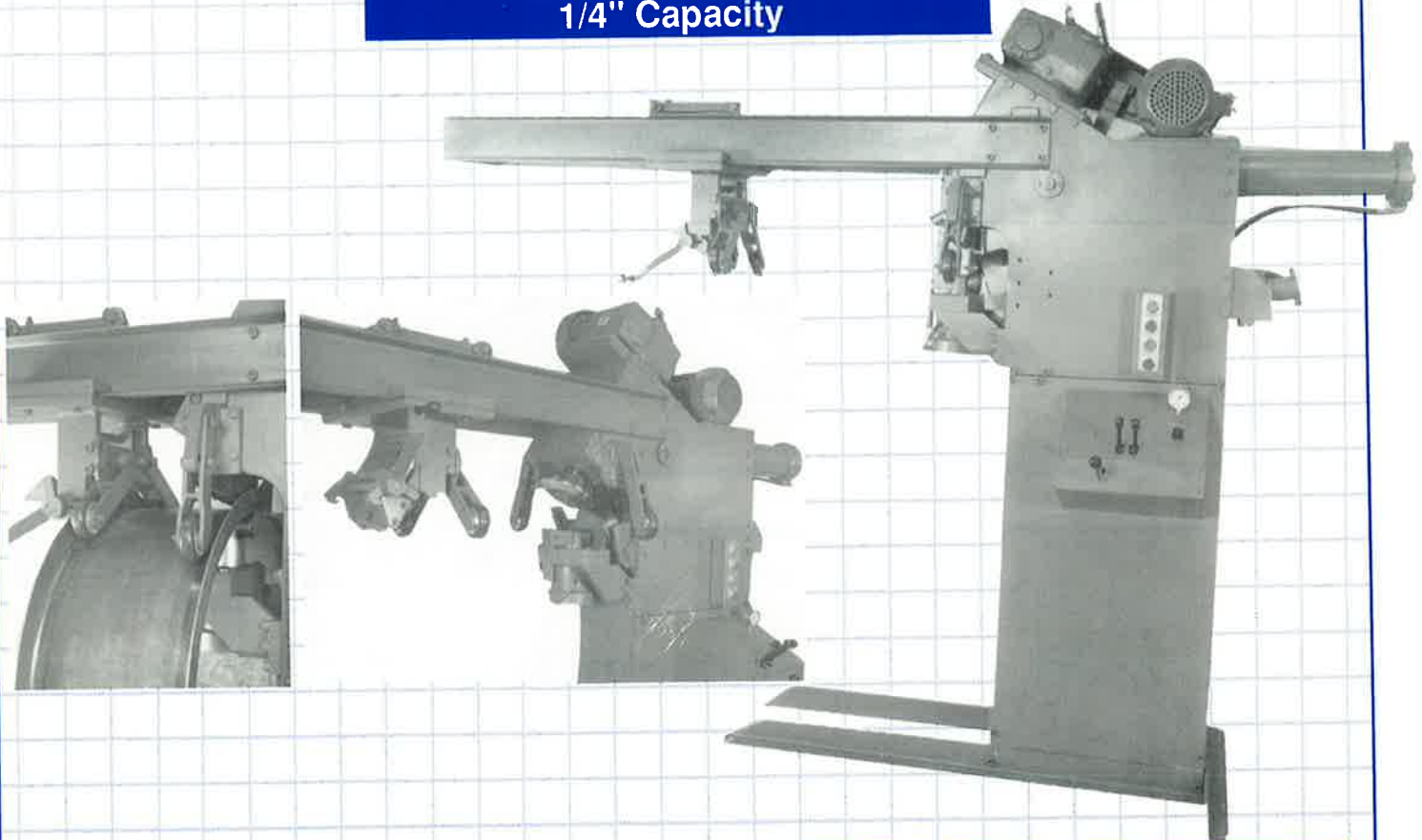

GENERAL INFORMATION

If your current manufacturing process requires you to weld rolled angles on to the ends of your tubes to produce a flanged tube, Blue Valley Machine & Manufacturing can save you time and money.

Since 1965, Blue Valley has been building a specialty machine that is used widely by tube axial fan manufacturers and a variety of other industries that require a fabricated, flanged tube in their product line.

The Blue Valley Tube Flanger is easy to operate and, for example, will create a flange on the ends of a 30" (760 mm) diameter tube in 3 to 4 minutes. Eliminate the time consuming, labor-intensive welding process, with a clean and precise flange on one or both ends of the tube. A flanged tube also has a neater, cleaner appearance...the sign of a superior quality finished product.

CAPACITY

The standard Blue Valley Tube Flanger will flange one or both ends, individually, of prepared tubes in a range of sizes, from 15" (380 mm) up to 60" (1525 mm) in diameter.



BLUE VALLEY
MACHINE & MANUFACTURING Co., INC.

Manufacturer of Metalforming Machines
Specializing in Tank Heads, Since 1928

6834 Truman Road
Kansas City, Missouri 64126
U.S.A.

Phone (816) 231-1480
Fax (816) 483-0059

CAPACITY

A 12" (300 mm) minimum diameter capacity is a factory installed option at time of purchase.

Tube lengths, from 8" (205 mm) up to 60" (1525 mm) can be flanged with standard length upper channels.

Tube thickness, from 1/16" (1.5 mm) to 1/4" (6 mm) can be flanged from mild steel. Other materials such as aluminum, galvanized steel and stainless steel are also suitable for use in the Blue Valley Tube Flanger.

Flange heights are primarily determined by the diameter and thickness of the tube. A flange height of 2 1/4" (57 mm) is the maximum the machine will allow. As the diameter and thickness of the tube being flanged decreases, so will the height of the flange.

1/4" Capacity Tube Flanger

- 5 HP—Drive Motor
- 1 HP, 10 Gal.—Free-standing Hydraulic Power Unit
- Crated Shipping Weight—4,000 lbs.

